

CUSTOMER

CAN ART STD.

DIE No.

EH04004

REV. No.

1

DESCRIPTION

3.000 x 2.000 x 0.250 RECT. TUBE w/ ROUNDED CORNERS

CUSTOMER PART No.

QUOTE No.

12-0583-1

PROPOSAL No.

H-26406

NOTE: BREAK ALL CORNERS WITH 0.015" (.38 MM) RADIUS UNLESS OTHERWISE NOTED. STANDARD TOLERANCES TO APPLY UNLESS OTHERWISE SPECIFIED.

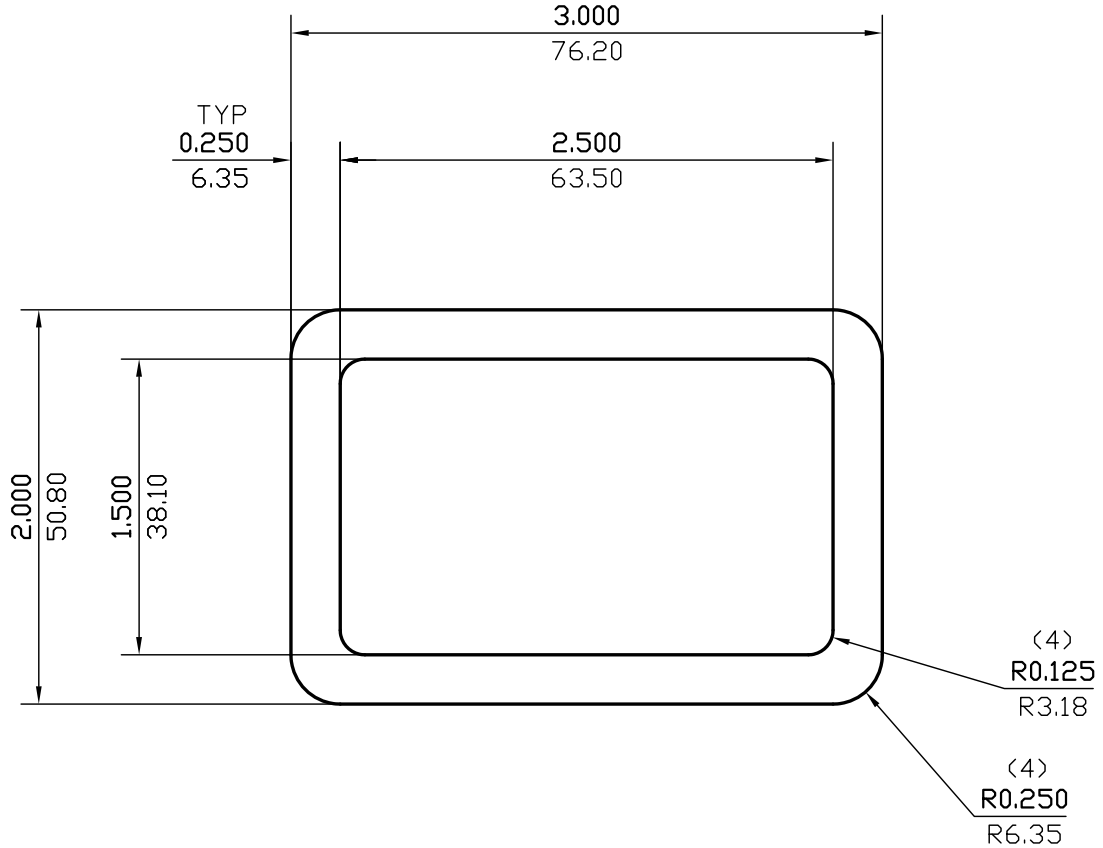

WALL THICKNESS 0.250 (6.35) EXCEPT AS SHOWN

DATE	REV	DESCRIPTION	BY
03/15/24	1	REMOVED ALLOY	JASON

EST.AREA	2.210	IN. ²	EST.AREA	1425.661	MM. ²
EST.WT.	2.608	LBS/FT.	EST.WT.	3.881	KG/M.
EST.PER.	17.356	IN.	EST.PER.	440.847	MM.
OUT PER.	9.571	IN.	OUT PER.	243.1	MM.
C.C.D.	3.414	IN.	C.C.D.	86.724	MM.
FINISH	M/F		ALLOY		
CKD BY	FACTOR 7	SCALE 1:1	DWN BY P.M.	DATE 06/20/2012	

CAN ART

ALUMINUM EXTRUSION INC.

85 PARKSHORE DRIVE
BRAMPTON, ONT L6T 5M1
TEL. NO. (905) 791-1464
FAX NO. (905) 791-9151
WEB: www.canart.com

THIS DRAWING IS NOT NECESSARILY A COPY OF YOUR ORIGINAL. PLEASE APPROVE DIMENSIONS AND TOLERANCES INDICATED. CAN ART ASSUMES NO RESPONSIBILITY EITHER TECHNICAL OR LEGAL FOR HAVING THIS SHAPE MADE. THE CUSTOMER AGREES TO FULLY PROTECT CAN ART ALUMINUM FROM CLAIMS OF OTHERS RESULTING FROM THIS SHAPE.

SIGNED: _____ DATE: _____